

Dealer's Manual

Nexus

Inter-8
Inter-7
Inter-5



CONTENTS

MODELS COVERED BY THIS DEALER'S MANUAL	4
IMPORTANT NOTICE	5
TO ENSURE SAFETY	6
LIST OF TOOLS TO BE USED	12
INSTALLATION	14
Installation of the sprocket to the hub	14
■ 7-speed hub, 5-speed hub	14
■ 8-speed hub	14
Installation of the cassette joint to the hub	15
■ 7-speed hub	15
■ 8-speed hub, 5-speed hub	16
Installing the Inter-M brake to the hub body	18
Installation of the hub to the frame	19
Installation of the disc brake rotor	22
■ Center lock type	22
■ 5 bolt type (with lock washer)	23
Installation of the lever	24
■ When equipped with mode switching mechanism	24
■ Installation of the lever	25
Installation of the shifting cable	26
Installing to the cassette joint	26
■ For CJ-NX10/CJ-8S20	26
■ For CJ-NX40/CJ-8S40	30
ADJUSTMENT	36
Adjusting the cassette joint	36
MAINTENANCE	40
Disconnecting the shifting cable when removing the rear wheel from the frame	40
■ For CJ-NX10/CJ-8S20	40
■ For CJ-NX40/CJ-8S40	41
Replacing the inner cable	43
■ REVOSHIFT lever	43
■ RAPIDFIRE Plus Shifting lever	46

Replacement and assembly of the indicator unit	47
■ Removal	47
■ Installation	48
Oil maintenance of the internal assembly	48

MODELS COVERED BY THIS DEALER'S MANUAL

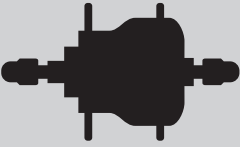
This Dealer's Manual is for the following models.

Part/Series		Inter-8	Inter-7	Inter-5
Internal geared hub 	Coaster brake + Disc brake	SG-C6000-8CD	-	-
	Disc brake	SG-C6000-8D	-	-
	Coaster brake	SG-C6000-8C SG-8C31	SG-C3000-7C SG-7C30	-
	Inter-M brake	SG-C6010-8R SG-C6000-8R SG-8R31 SG-8R36	SG-C3000-7R SG-7R50	SG-5R30 SG-5R35
	V-BRAKE	SG-C6010-8V SG-C6000-8V SG-8R31-VS SG-8R36-VS	-	SG-5R30-VS SG-5R35-VS
Shifting lever 	RAPIDFIRE Plus Shifting lever	-	SL-7S50	SL-5S50
Shifting lever 	REVOSHIFT lever	SL-8S31 SL-8S30 SB-8S20-A	SL-7S31 SL-7S30 SB-C3000-7	SL-5S30
Cassette joint		CJ-8S40 CJ-8S20	CJ-NX40 CJ-NX10	CJ-8S40 CJ-8S20

IMPORTANT NOTICE

- **This dealer's manual is intended primarily for use by professional bicycle mechanics.**

Users who are not professionally trained for bicycle assembly should not attempt to install the components themselves using the dealer's manuals.

If any part of the information on the manual is unclear to you, do not proceed with the installation. Instead, contact your place of purchase or a local bicycle dealer for their assistance.

- Make sure to read all instruction manuals included with the product.
- Do not disassemble or modify the product other than as stated in the information contained in this dealer's manual.
- All manuals and technical documents are accessible online at <https://si.shimano.com>.
- For consumers who do not have easy access to the internet, please contact a SHIMANO distributor or any of the SHIMANO offices to obtain a hardcopy of the User's Manual.
- Please observe the appropriate rules and regulations of the country, state or region in which you conduct your business as a dealer.

For safety, be sure to read this dealer's manual thoroughly before use, and follow it for correct use.

The following instructions must be observed at all times in order to prevent personal injury and physical damage to equipment and surroundings.

The instructions are classified according to the degree of danger or damage which may occur if the product is used incorrectly.

DANGER

Failure to follow the instructions will result in death or serious injury.

WARNING

Failure to follow the instructions could result in death or serious injury.

CAUTION

Failure to follow the instructions could cause personal injury or physical damage to equipment and surroundings.

TO ENSURE SAFETY

⚠ WARNING

- Be sure to follow the instructions provided in the manuals when installing the product.

It is recommended to use genuine Shimano parts only. If parts such as bolts and nuts become loose or damaged, the bicycle may suddenly fall over, which may cause serious injury.

In addition, if adjustments are not carried out correctly, problems may occur, and the bicycle may suddenly fall over, which may cause serious injury.

-  Be sure to wear safety glasses or goggles to protect your eyes while performing maintenance tasks such as replacing parts.

Be sure to also inform users of the following:

- Each bicycle may handle slightly differently depending on the model. Therefore, be sure to learn the proper braking technique (including brake lever pressure and bicycle control characteristics) and operation of your bicycle. Improper use of your bicycle's brake system may result in a loss of control or a fall, which could lead to severe injury. For proper operation, consult a professional bicycle dealer or the bicycle's owner's manual. It is also important to practice riding and braking, etc.
- The brake levers are equipped with a mode switching mechanism which can be used to make them compatible with cantilever brakes and roller brakes or V-BRAKE brakes with power modulator. (SB-8S20-A/ SB-C3000-7 is compatible with roller brakes or V-BRAKE brakes with power modulator. Please note that it is not compatible with cantilever brakes.)

If the incorrect mode is selected it may result in either excessive or insufficient braking force, which is highly dangerous.

Select the correct mode as shown in the illustrations.

Brake levers with mode switching mechanism can be assembled as shown in the illustrations.

Applicable brake:

Cantilever brakes
Roller brakes

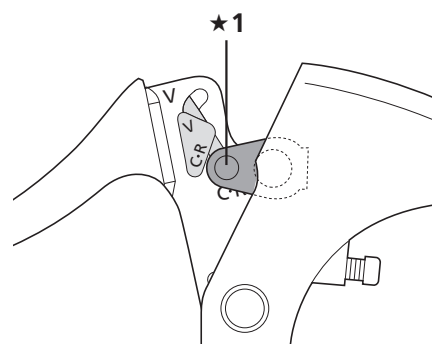

- ★1 C-R position
C: Mode position for compatibility with cantilever brakes
R: Mode position for compatibility with roller brakes

Applicable brake (for SB-8S20-A/SB-C3000-7):

Roller brakes

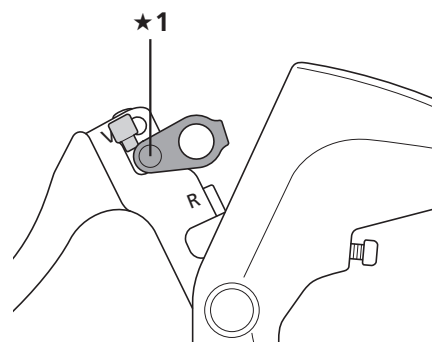

- ★1 R position
R: Mode position for compatibility with roller brakes

Applicable brake:

V-BRAKE brakes with power modulator

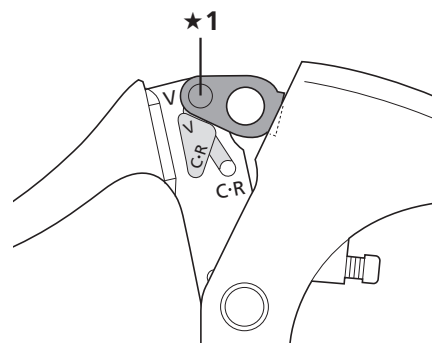

- ★1 V position
V: Mode position for compatibility with V-BRAKE brakes with power modulator

- Check that the wheels are fastened securely before riding the bicycle. If the wheels are loose in any way, they may come off the bicycle and cause serious injury.

For Installation to the Bicycle, and Maintenance:

- When securing the brake arm to the frame, be sure to use a brake arm clip that matches the size of the chainstay, and securely tighten them with the clip bolt and clip nut to the specified tightening torque. Use a lock nut with a nylon insert (self-locking nut) as the clip nut. It is recommended that Shimano made clip bolts, clip nuts, and arm clips be used. If the clip nut comes off the brake arm, or if the clip bolt or arm clip becomes damaged, the brake arm may rotate on the chainstay and cause the handlebars to jerk suddenly, or the bicycle wheel may lock and the bicycle may fall over, causing serious injury.
- When installing the hub to the frame, be sure to install the correct non-turn washers to the left and right sides, and securely tighten the hub nuts to the specified torques. If the non-turn washers are installed on one side only, or if the hub nuts are not tightened sufficiently, the non-turn washer may fall out, which could cause the hub axle to rotate and the cassette joint to turn, resulting in the handlebars being accidentally pulled by the shifting cable and an extremely serious accident.

Disc brake rotor

- Please make sure to keep your fingers away from the rotating disc brake rotor. The disc brake rotor is sharp enough to inflict severe injury to your fingers if caught in the openings of the disc brake rotor while it is moving.



- The calipers and disc brake rotor will become hot when the brakes are operated; do not touch them while riding or immediately after dismounting from the bicycle. Otherwise you may get burned.
- Be careful not to allow any oil or grease to get onto the disc brake rotor and brake pads. Otherwise the brakes may not work correctly.
- If any oil or grease gets on the brake pads, consult a dealer or an agency. Otherwise the brakes may not work correctly.

- If noise occurs during brake operation, the brake pads may have been worn down to the usable limit. After checking that the temperature of the brake system has cooled down sufficiently, check that the thickness of each pad is 0.5 mm or more. Or, consult a dealer or an agency.

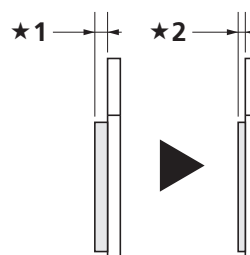

★1 2 mm
★2 0.5 mm

- If the disc brake rotor is cracked or deformed, immediately stop using the brakes and consult a dealer or an agency.
- If the disc brake rotor becomes worn down to a thickness of 1.5 mm or less, or if the aluminum surface appears, immediately stop using the brakes and consult a dealer or an agency. The disc brake rotor may break, and you may fall off the bicycle.

Coaster brake hub

- When using a reversed fork end, use a chain adjuster to remove excess slack from the chain.



Be sure to also inform users of the following:

- Be sure to shift the shifting lever one gear at a time. During shifting, reduce the force being applied to the pedals. If you try to force operation of the shifting lever or perform multi-shifting while the pedals are being turned strongly, your feet may come off the pedals and the bicycle may fall over, which could result in serious injury. Using the shifting lever to multi-shift to a light gear may also cause the outer casing to spring out of the shifting lever. This does not affect the capabilities of the shifting lever because the outer casing returns to the original position after shifting.

- If the brake is used frequently, the area around the brake may become hot. Do not touch the area around the brake for at least 30 minutes after riding the bicycle.

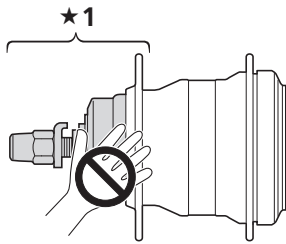

★1 Area around the brake

Coaster brake specifications

- Continuous application of the brakes when riding down long slopes will cause the internal brake parts to become very hot, weakening braking performance, and may also cause a reduction in the amount of brake grease inside the brake, leading to problems such as abnormally sudden braking.
- Spin the wheel and confirm that the braking force of the coaster brake is correct.

NOTE

Be sure to also inform users of the following:

- The gears can be shifted while lightly pedaling, but on rare occasions the pawls and ratchet inside the hub may produce some noise afterwards as part of normal gear shifting operation.
- The internal geared hub is not completely waterproof. Avoid using the hub in places where water might get inside and do not use high-pressure water to clean the hub, otherwise the internal mechanism may rust.
- Do not disassemble the hub. If you need to disassemble it, contact the place of purchase.
- All of the following occurrences are due to the internal gear-shifting structure and are not the failure of the internal components.

Phenomenon	Number of gears in hub	Type of hub		Gear positions where phenomenon might occur
		For coaster brakes	For roller brakes/V-BRAKE	
A clicking is felt in the pedal when you place your foot on a pedal and move the bicycle backward.	7-speed hub	×	-	All gear positions
Noise occurs when the pedals rotate.	7-speed hub	×	-	All gear positions
		-	×	2nd, 3rd, 4th, 5th, 6th, 7th
	8-speed hub	×	-	All gear positions except 1st
Noise occurs when the bicycle is pushed backward.	8-speed hub	×	×	5th, 6th, 7th, 8th
The hub has a built-in mechanism that supports gear shifting and when the mechanism operates during gear shifting, noise and vibrations occur.	8-speed hub	×	×	All gear positions
Depending on gear position, gear-shifting may feel different.	7-speed hub	×	×	All gear positions
	8-speed hub	×		
	5-speed hub	-		
Noise occurs when pedal rotation is stopped during riding.	7-speed hub	×	×	All gear positions
	8-speed hub	×	-	
	5-speed hub	-	×	4th, 5th

- Products are not guaranteed against natural wear and deterioration from normal use and aging.
- For maximum performance we highly recommend Shimano lubricants and maintenance products.

Coaster brake specifications

- If the wheels are not rotating smoothly, you need to replace or grease the brake shoes. Consult the dealer where you made the purchase.

For Installation to the Bicycle, and Maintenance:

- The cassette joint should only be used with sprockets with 16T to 23T.
- It is recommended that the chainring of the front be set to the following gear ratio.
7-speed, 8-speed: approx. 2.1
5-speed: approx. 2.0

Example) For 26 inch wheels

Front		36T	38T	46T
Rear	7-speed, 8-speed	16T	18T	22T
	5-speed	18T	19T	23T

- To maintain the product in good working order, it is recommended to have the place of purchase or a distributor carry out maintenance such as lubrication of the internal parts about once a year from the first time of use (once every 2,000 km if the bicycle is used very frequently). If the bicycle is used under harsh conditions, more frequent maintenance is required. Also, for carrying out maintenance, the use of SHIMANO internal geared hub grease or a lubrication kit is recommended. If SHIMANO grease or a SHIMANO lubrication kit is not used, problems such as a malfunction in gear shifting may occur.
- If the wheel becomes difficult to turn, lubricate it with grease.
- The gears should be periodically washed with a neutral detergent. In addition, cleaning the chain with neutral detergent and lubricating it can be an effective way of extending the life of the gears and the chain.
- If the chain keeps coming off the gears during use, replace the gears and chain.

Coaster brake specifications











- Use a wheel with 3x or 4x spoke lacing. Wheels with radial lacing cannot be used. Otherwise, the spokes or the wheel may get damaged, or noise may occur when braking.
- If the wheel becomes difficult to turn, you should replace the brake shoes or lubricate with grease.
- Use only the specified grease for the brake shoes and when using a lubrication kit, remove the brake shoes to avoid contact with the oil.

The actual product may differ from the illustration because this manual is intended mainly to explain the procedures for using the product.

LIST OF TOOLS TO BE USED

LIST OF TOOLS TO BE USED

The following tools are needed for installation, adjustment, and maintenance purposes.

Tool		Tool		Tool	
	2 mm hexagon wrench		Screwdriver[#1]		Adjustable wrench
	3 mm hexagon wrench		Screwdriver[#2]		TL-CJ40 (Y70898020)
	5 mm hexagon wrench		TL-LR10		
	10 mm spanner		Hexalobular[#25]		

INSTALLATION

INSTALLATION

Installation of the sprocket to the hub

■ 7-speed hub, 5-speed hub

1. Place right-hand dust cap onto the driver on the right side of the hub body. Next, install the sprocket and secure it in place with the snap ring.

Specifications	Applicable sprockets	
	Outward assembling	Inward assembling
7-speed	16T-23T	18T-23T
5-speed	16T-23T	

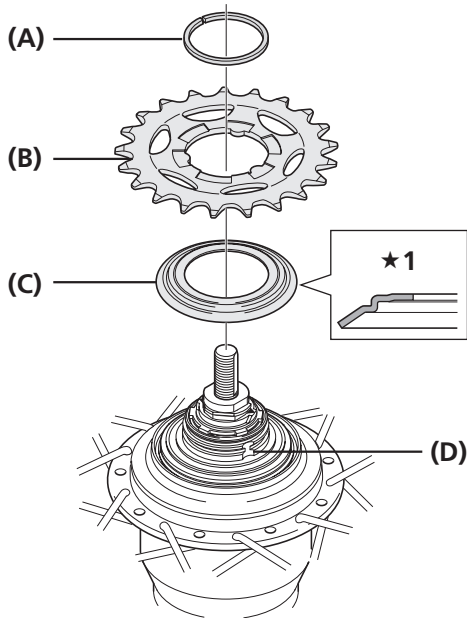

★1 Note the direction

- (A) Snap ring
- (B) Sprocket
- (C) 7-speed: Right-hand dust cap C
5-speed: Right-hand dust cap D
- (D) Driver

■ 8-speed hub

For specification A

1. Place right-hand dust cap C onto the driver on the right side of the hub body. Next, install the sprocket and secure it in place with the snap ring.

Specifications	Applicable sprockets	
	Outward assembling	Inward assembling
A	16T-23T	20T-23T

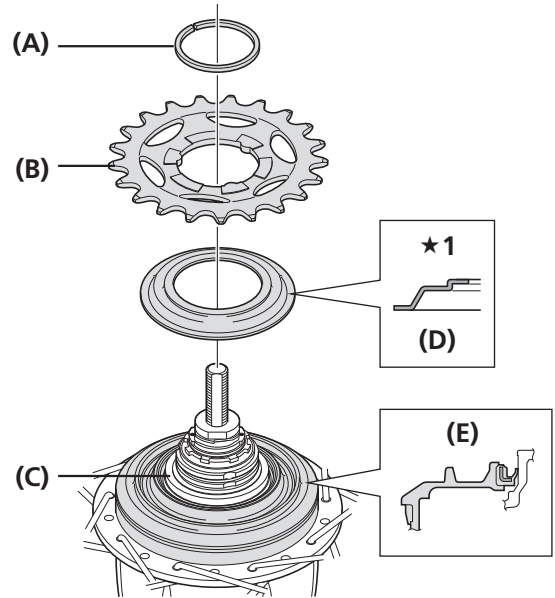

★1 Note the direction

- (A) Snap ring
- (B) Sprocket
- (C) Driver
- (D) Right-hand dust cap C
- (E) Right-hand dust cap A

NOTE

If the sprocket is an inward assembling sprocket with 19T or fewer or for belt drive specifications, right-hand dust cap A will come into contact with the chain or pulley so specification B should be used instead.

For specification B

1. Place right-hand dust cap onto the driver on the right side of the hub body. Next, install the sprocket and secure it in place with the snap ring.

Specifications	Applicable sprockets	
	Outward assembling	Inward assembling
B	16T-23T	

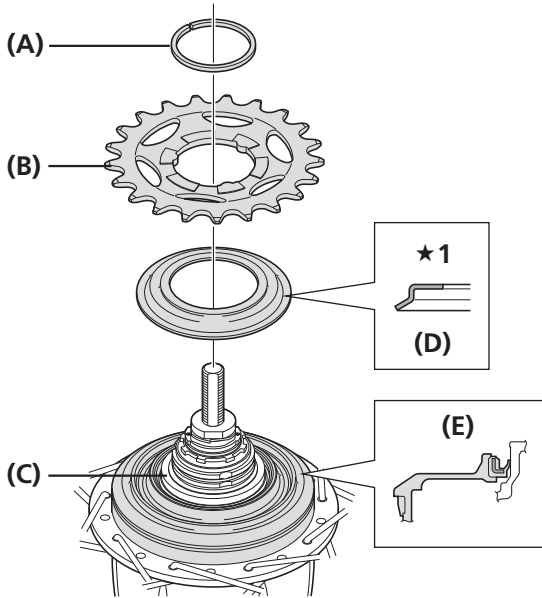

★1 Note the direction

- (A) Snap ring
- (B) Sprocket
- (C) Driver
- (D) Right-hand dust cap B
- (E) Right-hand dust cap A

NOTE

If the sprocket is an inward assembling sprocket with 16T and 3 mm teeth or for belt drive specifications, remove right-hand dust cap B before use.

Installation of the cassette joint to the hub

7-speed hub

1. Install the driver cap to the driver on the right side of the hub body. Next, turn the pulley of the cassette joint in the direction of the arrow so that the yellow ● mark is aligned with the yellow ▲ mark, and then align the yellow ▲ marks on the cassette joint with the yellow ▲ marks on the right side of the hub body.

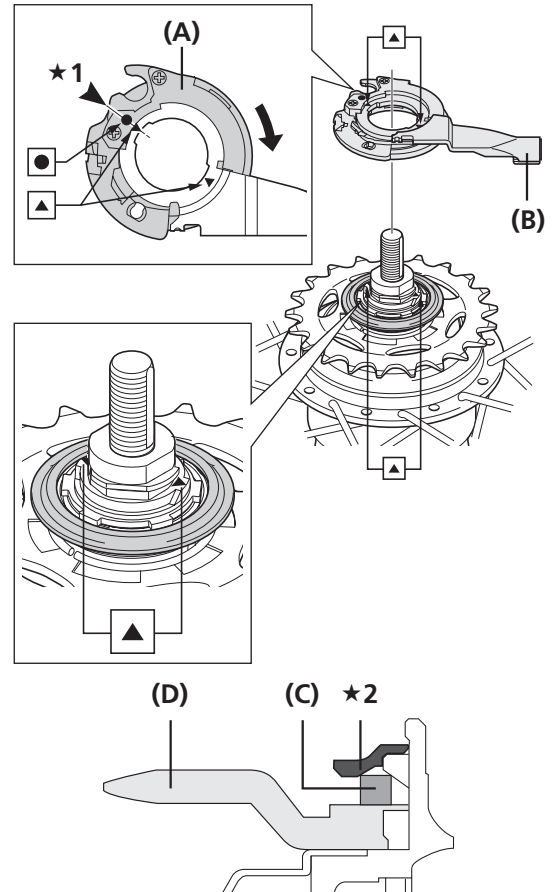

★1 Should be aligned

★2 Install the driver cap in this position.

- (A) Pulley
- (B) Cassette joint
- (C) Snap ring
- (D) Sprocket

- Secure the cassette joint to the hub with the cassette joint mounting ring. When installing the cassette joint mounting ring, align the yellow ● mark with the yellow ● mark on the pulley of the cassette joint, and then turn the cassette joint mounting ring 45° clockwise.

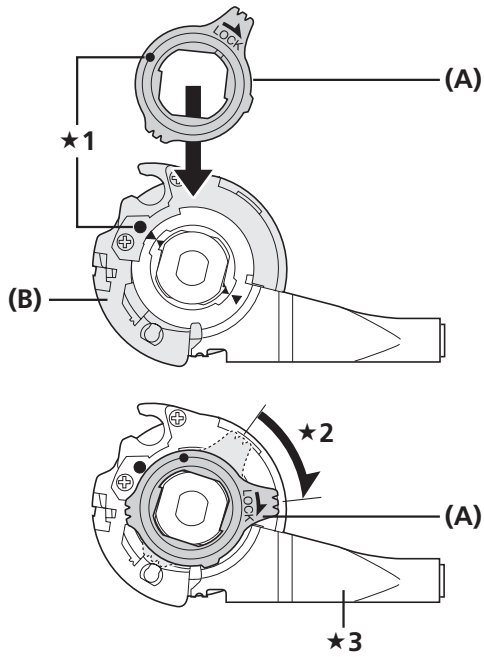

- ★1 Align the yellow ● marks to install.
- ★2 Turn 45°
- ★3 Fit the cassette joint bracket securely.

(A) Cassette joint mounting ring
 (B) Pulley

■ 8-speed hub, 5-speed hub

- Install the driver cap to the driver on the right side of the hub body.

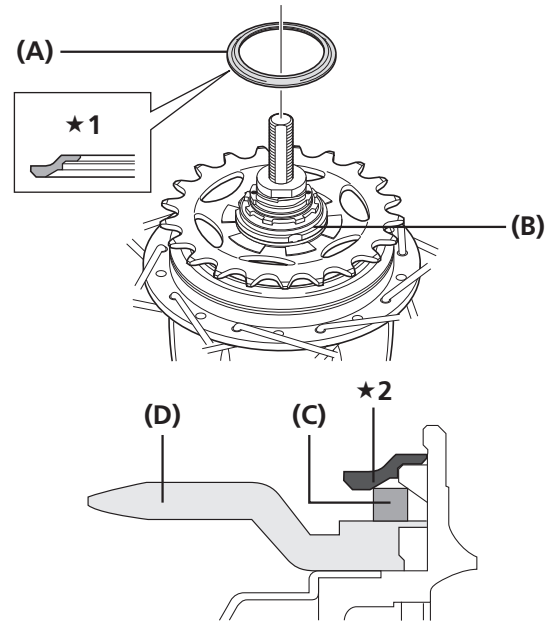

- ★1 Note the direction
- ★2 Install the driver cap in this position.

(A) Driver cap
 (B) Driver
 (C) Snap ring
 (D) Sprocket

2. Turn the cassette joint pulley in the direction of the arrow in the illustration to align the red ● marks on the pulley and the bracket and then with the cassette joint in this position, install it with the red ● marks on the cassette joint aligned with the red ● marks on the right side of the hub body.

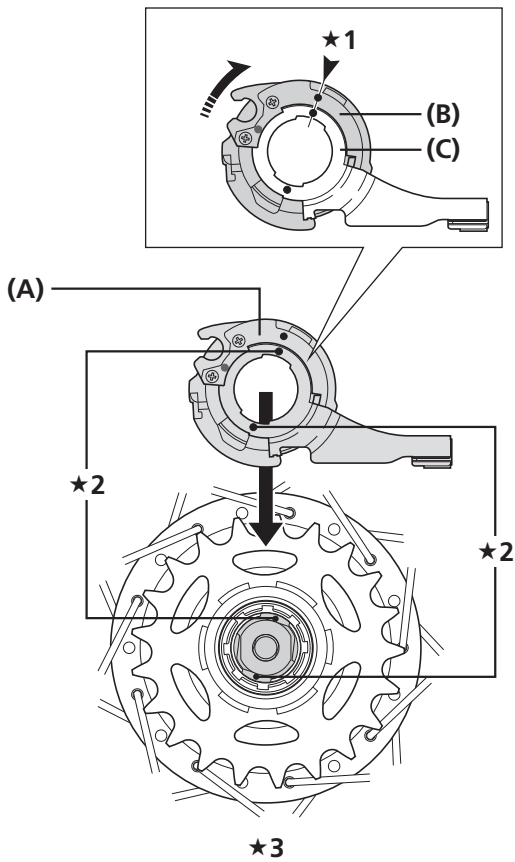

- ★1 Should be aligned
- ★2 Align the red ● marks to install.
- ★3 Right side of the hub body

(A) Cassette joint
(B) Pulley
(C) Bracket

3. Secure the cassette joint to the hub with the cassette joint mounting ring. When installing the cassette joint mounting ring, align the yellow ● mark with the yellow ● mark on the pulley of the cassette joint, and then turn the cassette joint mounting ring 45° clockwise.

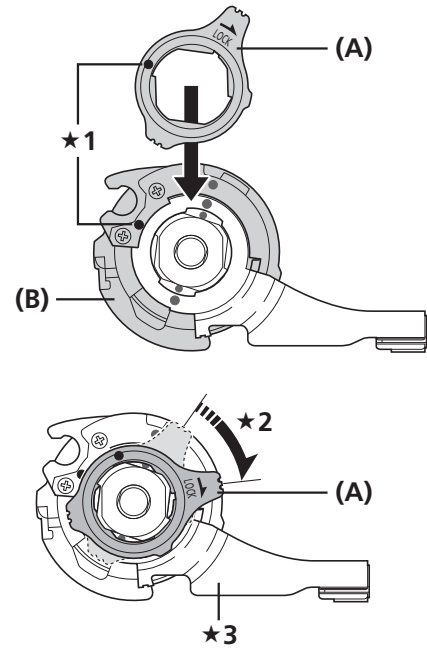

- ★1 Align the yellow ● marks to install.
- ★2 Turn 45°
- ★3 Fit the cassette joint bracket securely.

(A) Cassette joint mounting ring
(B) Pulley

Installing the Inter-M brake to the hub body

1. Engage the serrations on the hub body with the serrations on the Inter-M brake, and then provisionally tighten the brake unit fixing nut.

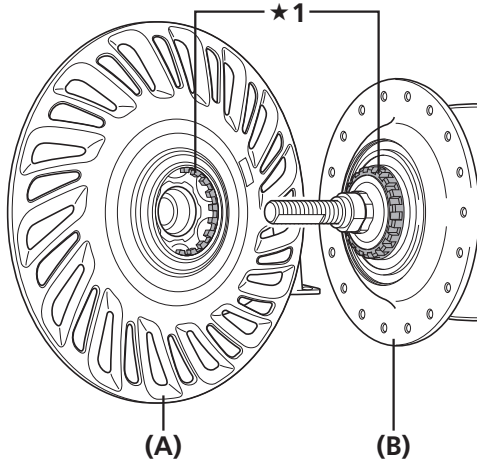

★1 Align the serrations

(A) Inter-M brake

(B) Hub body

Installation of the hub to the frame

1. Mount the chain on the sprocket, and then set the hub axle into the fork end.

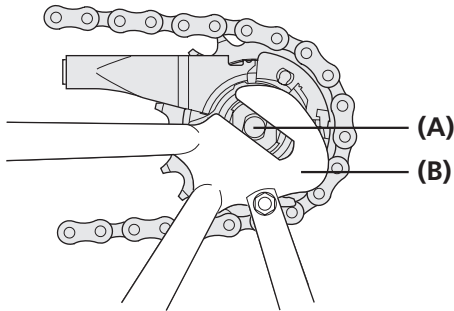

- (A) Hub axle
- (B) Fork end

2. Place non-turn washers and onto the right and left sides of the hub axle. At this time, turn the cassette joint so that the protrusions of the non-turn washers fit into the grooves in the fork ends and align the joint to be almost parallel to the chainstay.

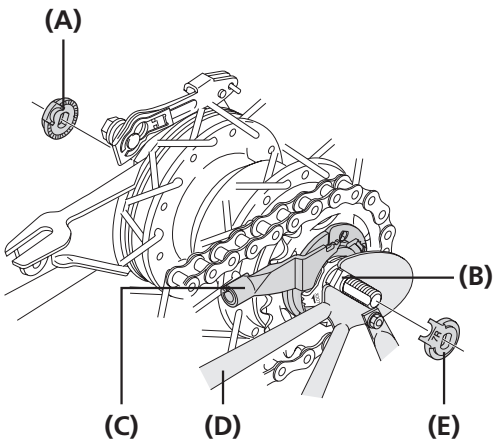

- (A) Non-turn washer (for left-side use)
- (B) Groove in fork end
- (C) Cassette joint
- (D) Chainstay
- (E) Non-turn washer (for right-side use)

NOTE

When installing parts such as a mudguard stay to the hub axle, install them in the order shown in the illustration below.

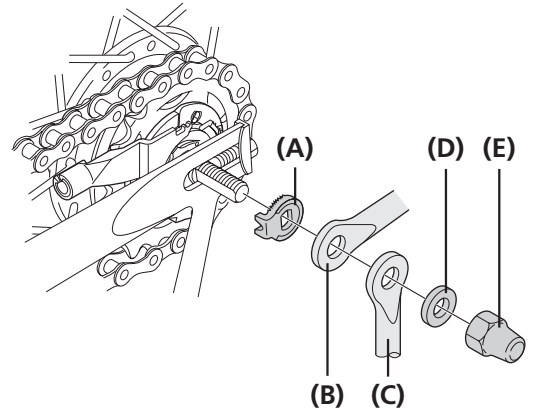

- (A) Non-turn washer
- (B) Mudguard stay
- (C) Carrier stay
- (D) Washer
- (E) Cap nut

TECH TIPS

- Use a non-turn washer that matches the shape of the fork end.
- Different non-turn washers are used for the left and right sides.

Fork end	Non-turn washer		
	Mark/Color		Size
	For right	For left	
Standard	5R/Yellow	5L/Brown	$\theta \leq 20^\circ$
	7R/Black	7L/Gray	$20^\circ \leq \theta \leq 38^\circ$
Reversed	6R/Silver	6L/White	$\theta = 0^\circ$
Reversed (Full chain case)	5R/Yellow	5L/Brown	$\theta = 0^\circ$
Vertical	8R/Blue	8L/Green	$\theta = 60^\circ - 90^\circ$

Note: Vertical type does not include the coaster specifications.



★1 Mark

- The protrusion should be on the fork end side.
- Install the non-turn washer so that the protrusion fits securely in the fork end groove at the front and back sides of the hub axle.

In the case of Inter-M brake specifications

- Attach the brake arm of the Inter-M brake to the chainstay with the brake arm clip.
- Next, temporarily fix the clip bolt and clip nut by lightly tightening them.
- If the hub nuts are cap nuts, use a frame with fork ends that are at least 7 mm thick.
- Check that the brake unit is firmly secured to the hub with the brake unit fixing washer.

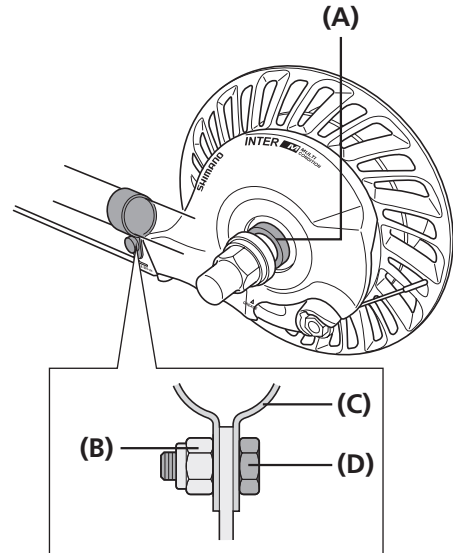

- (A) Brake fixing washer (insert manually)
- (B) Clip nut
- (C) Arm clip
- (D) Clip bolt (M6 × 16 mm)

3. Take up slack in the chain and secure the wheel to the frame with the cap nut.

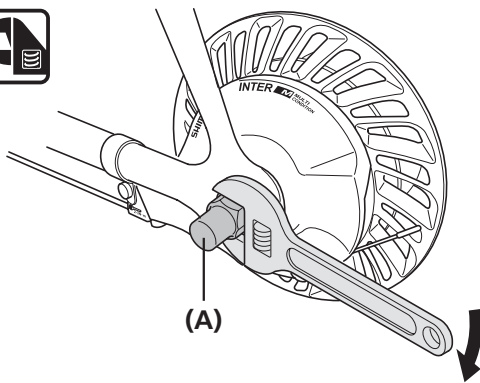

(A) Hub nut

Tightening torque
Adjustable wrench
30 - 45 N·m

NOTE

Check that the wheel is fixed securely to the frame with the hub nut.

4. Fix the brake arm securely to the chainstay with the arm clip.

Check that the brake arm is securely fastened to the chainstay with the brake arm clip. If it is not installed correctly, braking performance will suffer.

- If excessive force is applied to the brake arm to secure it, the wheel will make noise and become difficult to turn.

Be careful not to apply excessive force when installing.

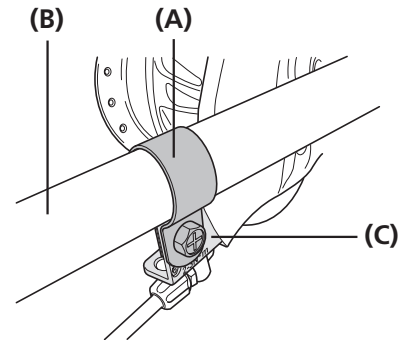

(A) Arm clip
 (B) Chainstay
 (C) Brake arm

Tightening torque
Screwdriver[#1]
10 mm spanner
2 - 3 N·m

In the case of coaster brake specifications

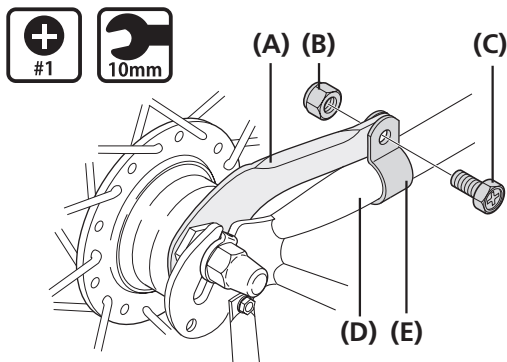

- (A) Brake arm
- (B) Clip nut
- (C) Clip bolt
- (D) Chainstay
- (E) Arm clip

Tightening torque

Screwdriver[#1]
10 mm spanner
2 - 3 N·m

⚠ WARNING

When securing the brake arm to the frame, be sure to use a brake arm clip that matches the size of the chainstay, and securely tighten them with the clip bolt and clip nut to the specified tightening torque.

Use a lock nut with a nylon insert (self-locking nut) as the clip nut. It is recommended that Shimano made clip bolts, clip nuts, and arm clips be used.

If the clip nut comes off the brake arm, or if the clip bolt or arm clip becomes damaged, the brake arm may rotate on the chainstay and cause the handlebars to jerk suddenly, or the bicycle wheel may lock and the bicycle may fall over, causing serious injury.

NOTE

- When installing the arm clip, securely tighten the clip bolt while holding the clip nut with a 10 mm spanner.
- After installing the arm clip, check that the clip bolt protrudes about 2 to 3 mm from the end face of the clip nut.

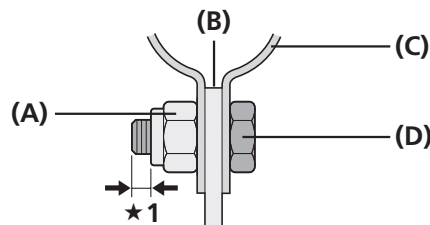

★1 2 - 3 mm

- (A) Clip nut
- (B) Brake arm
- (C) Arm clip
- (D) Clip bolt (M6 × 16 mm)

- Before using the Coaster Brake, check that the brake works properly and that the wheel turns smoothly.

Installation of the disc brake rotor

■ **Center lock type**

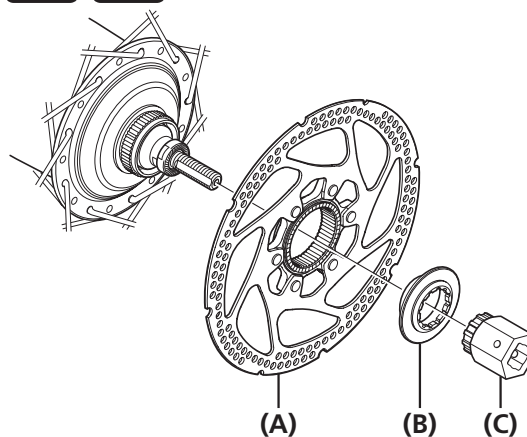

- (A) Disc brake rotor
- (B) Disc brake rotor fixing lock ring
- (C) TL-LR10

Tightening torque

Adjustable wrench
TL-LR10
40 N·m

■ 5 bolt type (with lock washer)

1. Attach the disc brake rotor and the disc brake rotor lock washers to the hub, and then tighten them on with a bolts.

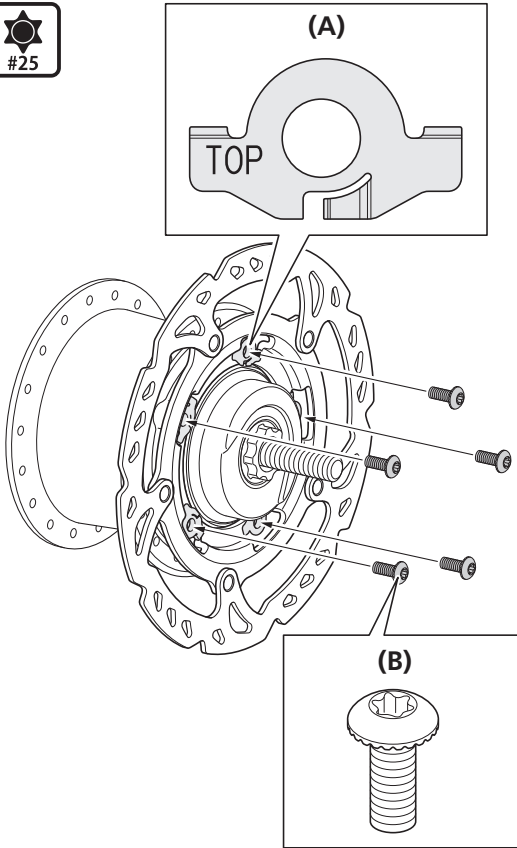

- (A) Lock washer
- (B) Disc brake rotor fixing bolt

Tightening torque
Hexalobular[#25]
2 - 4 N·m

NOTE

- Fit the lock washers so that the marking "TOP" is visible.
- Ensure that the hooked parts of the lock washer are securely caught on the notches in the disc brake rotor and then tighten on the lock washer with the disc brake rotor fixing bolt. If tightened while the hooked parts are against the surface of the disc brake rotor, the washer and its hooked parts will become deformed.

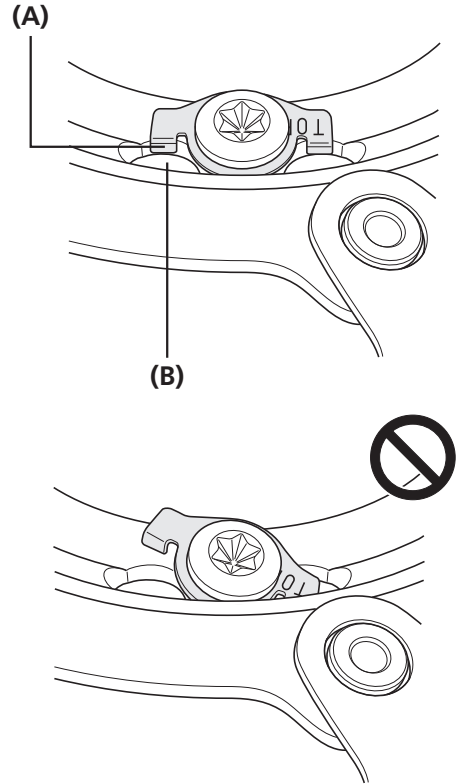

- (A) Hooked part of washer
- (B) Notch in disc brake rotor

- The lock washers are not reusable. Always use new lock washers when installing/re-installing the disc brake rotor.
- Use the dedicated disc brake rotor fixing bolts.

2. Wear gloves and turn the disc brake rotor clockwise with some force. At this time, tighten on the disc brake rotor fixing bolts in the order indicated in the illustration.

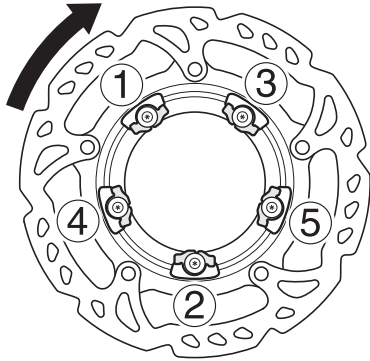

Installation of the lever

■ When equipped with mode switching mechanism

1. Use screwdriver[#1] to loosen the screw.



2. Set the mode switch to the mode position for the brake installed.



TECH TIPS

For V-BRAKE brakes



For caliper brakes/cantilever brakes/roller brakes



■ Installation of the lever

Install the lever as shown in the illustration.

For REVOSHIFT lever

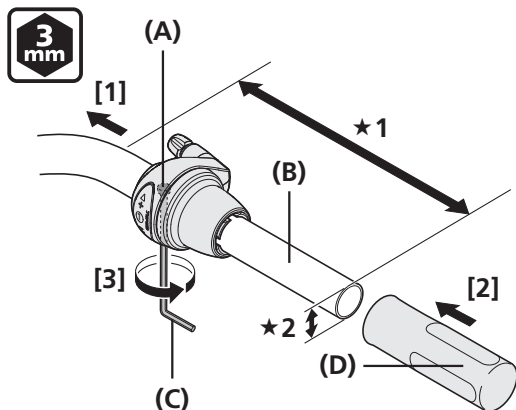

★1 166 mm or more

★2 $\varnothing 22.2$ mm

- (A) Fixing bolt
- (B) Handlebar
- (C) 3 mm hexagon wrench
- (D) Half grip

Tightening torque

3 mm hexagon wrench

2 - 2.5 N·m

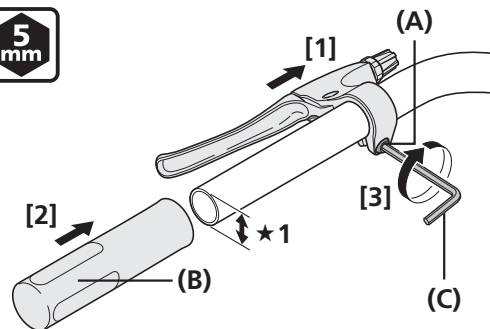

★1 $\varnothing 22.2$ mm

- (A) Fixing bolt
- (B) Grip
- (C) 5 mm hexagon wrench

Tightening torque

5 mm hexagon wrench

6 - 8 N·m

TECH TIPS

- If using Shimano half grip, the straight section of the handlebar should be 166 mm or longer. Attach the REVOSHIFT lever to this straight section.
- Leave a gap of 0.5 mm between the REVOSHIFT lever and the half grip.

For RAPIDFIRE Plus

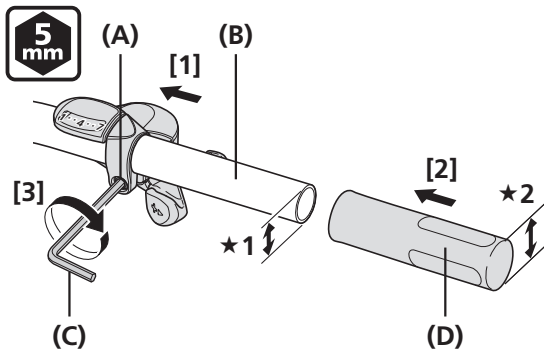

- ★1 Ø22.2 mm
- ★2 Ø32 mm or less

- (A) Fixing bolt
- (B) Handlebar
- (C) 5 mm hexagon wrench
- (D) Grip

Tightening torque

5 mm hexagon wrench
5 - 7 N·m

TECH TIPS

Use a handlebar grip with an outer diameter of Ø32 mm or less.

Installation of the shifting cable

For information on how to replace the inner cable, refer to the maintenance section.

* Use a shifting cable with one inner cable drum.

Shifting cable with one inner cable drum:
 OT-SP41

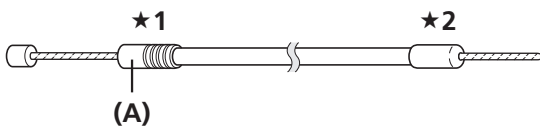

- ★1 Shifting lever side
- ★2 Cassette joint side

- (A) Sealed outer cap

NOTE

Make sure that the sealed outer cap is at the shifting lever end.

Installing to the cassette joint

■ For CJ-NX10/CJ-8S20

1. Pass the inner cable through the OT-SP41 outer casing to the end with the plastic cap.

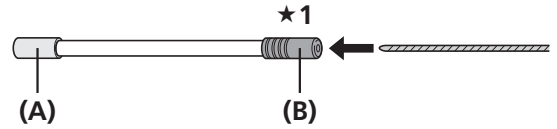

- ★1 Lever side

- (A) Aluminum cap
- (B) Plastic cap

TECH TIPS

Cutting the outer casing

If cutting the outer casing, cut it near the end with the plastic cap while the cap is still attached.

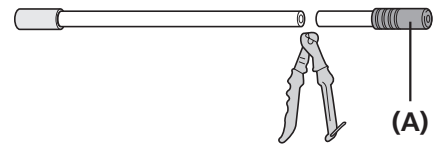

- (A) Plastic cap

After cutting, make the cut end perfectly round and attach the plastic cap.

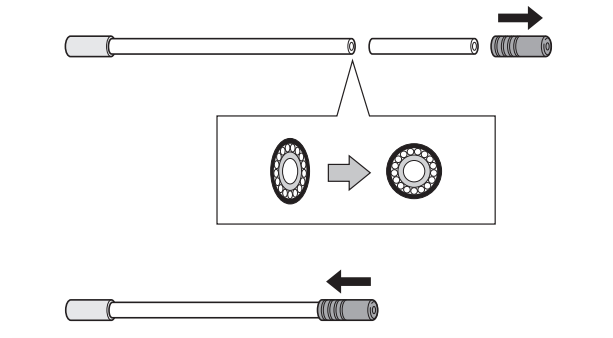

2. Set the REVOSHIFT lever/shifting lever to 1.

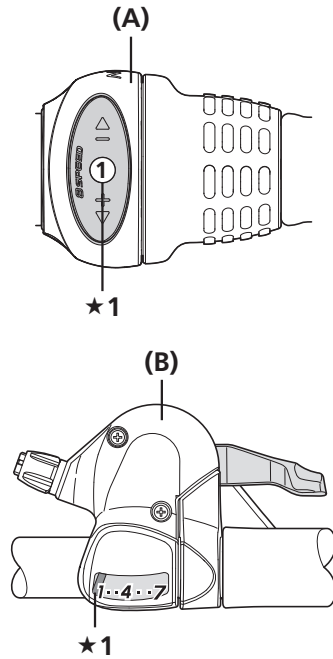

★1 Set to 1

- (A) REVOSHIFT lever
- (B) RAPIDFIRE Plus shifting lever

3. After checking that the end of the outer casing is securely set in the cable adjustment barrel of the REVOSHIFT lever/shifting lever, attach the inner cable fixing bolt unit to the inner cable. When installing the inner cable fixing bolt unit, use the setting tool TL-CJ40 (Y70898020). For CJ-NX10 and CJ-8S20, use the front side of TL-CJ40.

NOTE

- The tool is shipped ready to be used for CJ-NX10 and CJ-8S20.

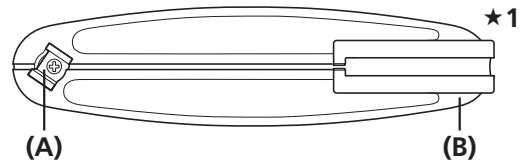

★1 Front side

- (A) Nut fitting
- (B) TL-CJ40

- This inner cable fixing bolt unit is designed only for CJ-NX10, CJ-NX40, CJ-8S20, and CJ-8S40. 11-speed fixing bolt units cannot be used.

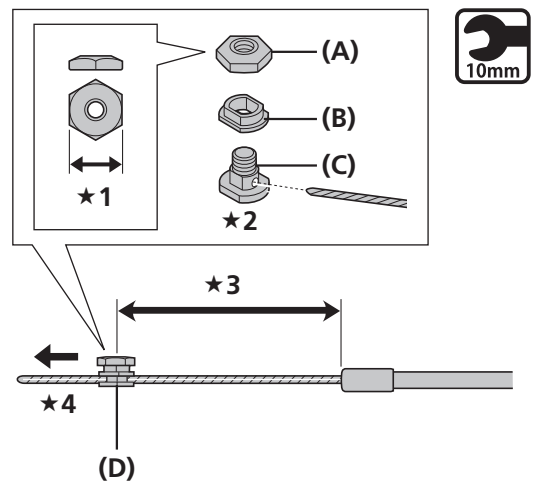

- ★1 10 mm
- ★2 Pass the inner cable through the hole.
- ★3 101 mm
- ★4 Pull the inner cable while attaching the inner cable fixing bolt unit.

- (A) Inner cable fixing nut (Black)
- (B) Inner cable fixing washer (Silver)
- (C) Inner cable fixing bolt (Silver)
- (D) Inner cable fixing bolt unit

Tightening torque

10 mm spanner
3.5 - 5.5 N·m

4. Bring the cable around to the cassette joint pulley, hold it so that the inner cable fixing nut is facing outwards (towards the fork end), and then slide the flats part of the inner cable fixing washer into the gap in the pulley.

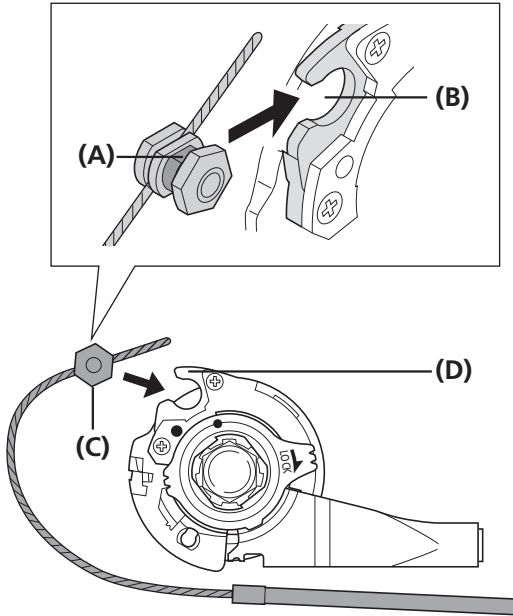

- (A) Flats part of inner cable fixing washer
- (B) Gap in pulley
- (C) Inner cable fixing nut
- (D) Pulley

5. Turn the cable 60° counterclockwise and attach it to the hook.

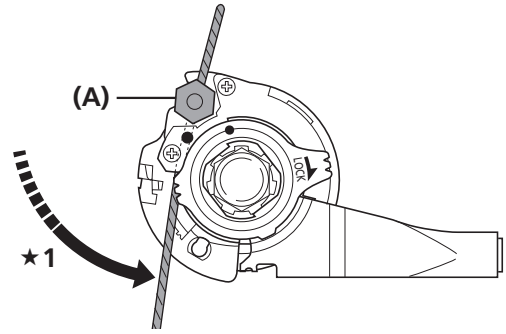

★1 Turn the cable 60°

(A) Hook

6. Attach the inner cable to the pulley as shown in the illustration, pass the inner cable through the slit in the cassette joint bracket, and then insert the end of the outer casing securely into the outer casing holder.

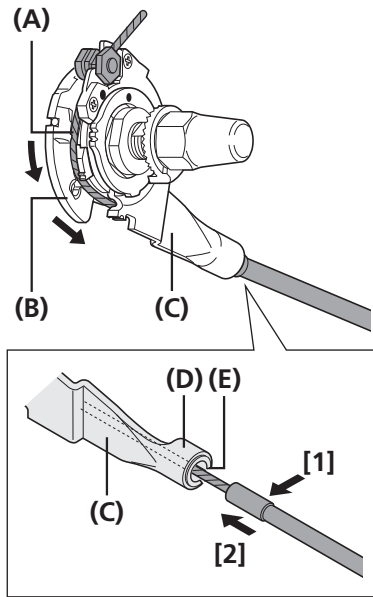

- (A) Inner cable
- (B) Pulley
- (C) Bracket
- (D) Outer casing holder
- (E) Slit

NOTE

Check that the inner cable is correctly seated inside the pulley guide.

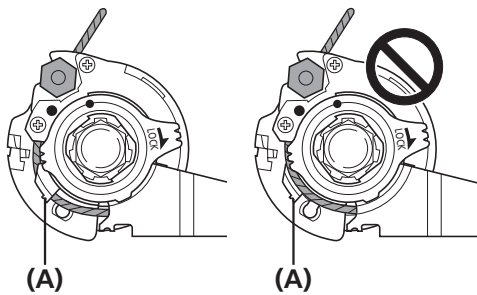

- (A) Guide

TECH TIPS

When it is easier to insert the outer casing into the outer casing holder

Insert the outer casing into the outer casing holder [1]. Next, insert a 2 mm hexagon wrench or a #14 spoke into the hole in the cassette joint pulley, and turn the pulley [2] so that the inner cable fixing bolt unit fits into the gap in the pulley [3].

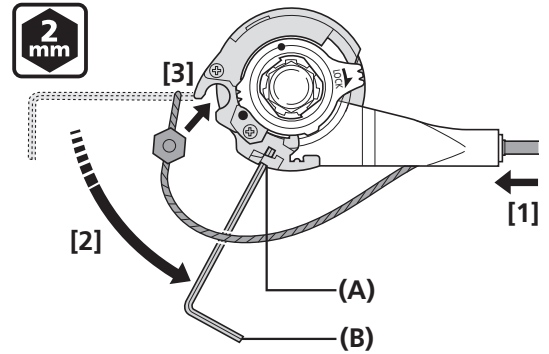

- (A) Hole in pulley
- (B) 2 mm hexagon wrench or #14 spoke

7. Finally, fix the cable on the frame with the outer casing bands.

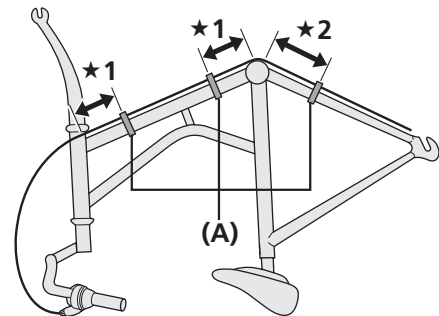

- *1 10 cm
- *2 15 cm

- (A) Outer casing bands

■ For CJ-NX40/CJ-8S40

1. Set the REVOSHIFT lever/shifting lever to 1.

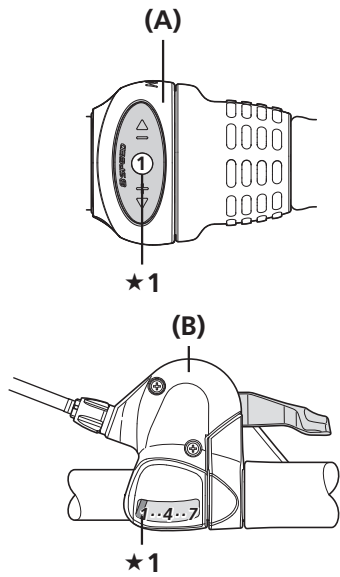

★1 Set to 1

- (A) REVOSHIFT lever
- (B) RAPIDFIRE Plus shifting lever

2. Install the rubber cover and rubber bellows to the outer casing holder.

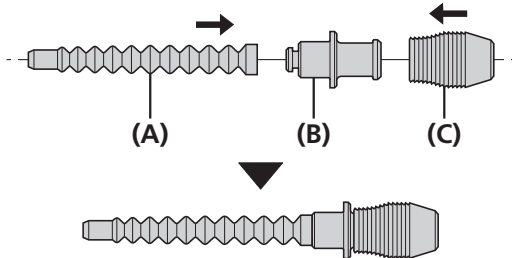

- (A) Rubber bellows
- (B) Outer casing holder
- (C) Rubber cover

3. Wipe off any grease on the inner cable.

NOTE

Pay attention to the end of the inner cable

Use a new inner cable; do not use a cable which has had its end cut off.



4. While holding the end of the rubber bellows, insert the inner cable.

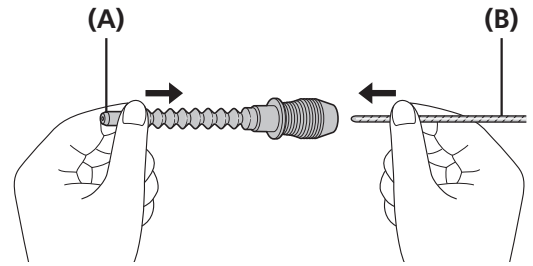

- (A) End of rubber bellows
- (B) Inner cable

NOTE

Be careful not to pierce the rubber bellows with the end of the inner cable at this time.

5. Slide the rubber bellows onto the inner cable.

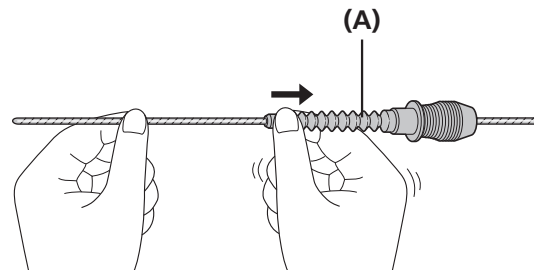

- (A) Rubber bellows

6. Insert the outer casing into the rubber cover and set it into the outer casing holder. Push the outer casing so that it securely touches the holder.

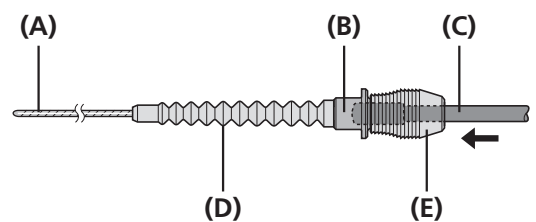

- (A) Inner cable
- (B) Outer casing holder
- (C) Outer casing
- (D) Rubber bellows
- (E) Rubber cover

7. After checking that the end of the outer casing is securely set in the cable adjustment barrel of the shifting lever, attach the inner cable fixing bolt unit to the inner cable.
When installing the inner cable fixing bolt unit, use the setting tool TL-CJ40 (Y70898020).

NOTE

- TL-CJ40 is shipped ready to be used for CJ-NX10 and CJ-8520.
- For CJ-NX40 and CJ-8540, use the reverse side of TL-CJ40. Replace the nut fitting as shown in the illustration.

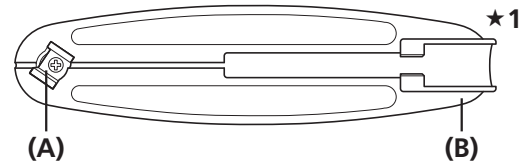

★1 Reverse side

- | |
|-----------------|
| (A) Nut fitting |
| (B) TL-CJ40 |

- This inner cable fixing bolt unit is designed only for CJ-NX10, CJ-NX40, CJ-8520, and CJ-8540. 11-speed fixing bolt units cannot be used.

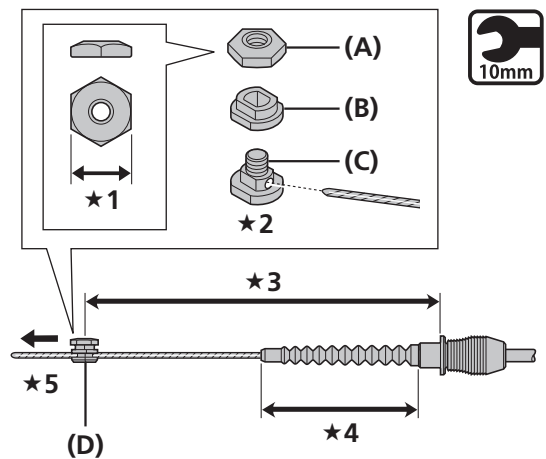

- ★1 10 mm
- ★2 Pass the inner cable through the hole.
- ★3 127 mm
- ★4 63 mm or less
- ★5 Pull the inner cable while attaching the inner cable fixing bolt unit.

- | |
|--|
| (A) Inner cable fixing nut (Black) |
| (B) Inner cable fixing washer (Silver) |
| (C) Inner cable fixing bolt (Silver) |
| (D) Inner cable fixing bolt unit |

Tightening torque

10 mm spanner

3.5 - 5.5 N·m

8. Bring the cable around to the cassette joint pulley, hold it so that the inner cable fixing nut is facing outwards (towards the fork end), and then slide the flats part of the inner cable fixing washer into the gap in the pulley.

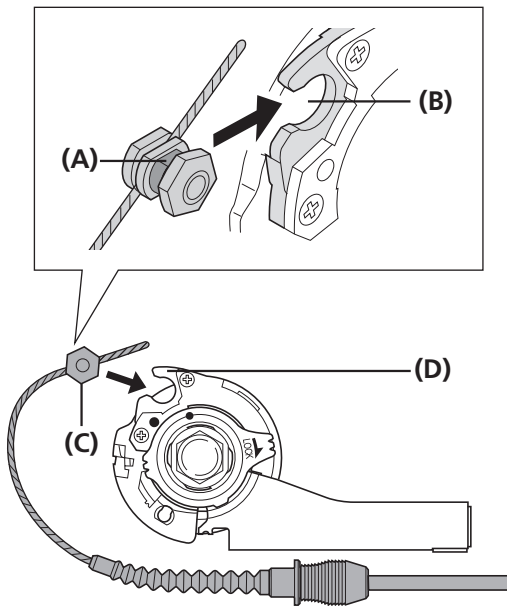

- (A) Flats part of inner cable fixing washer
 (B) Gap in pulley
 (C) Inner cable fixing nut
 (D) Pulley

9. Turn the cable 60° counterclockwise and attach it to the hook.

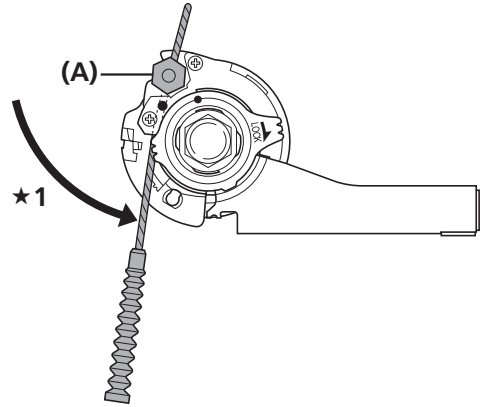

★1 Turn the cable 60°

(A) Hook

10. Mount the inner cable into the pulley as shown in the illustration.

Holding the rubber cover, insert the rubber bellows part of the inner cable into the slit in the cassette joint bracket (see [1] in the illustration). Next, insert the outer casing holder securely into the outer casing holder section (see [2] in the illustration). Be careful not to damage the rubber bellows at this time.

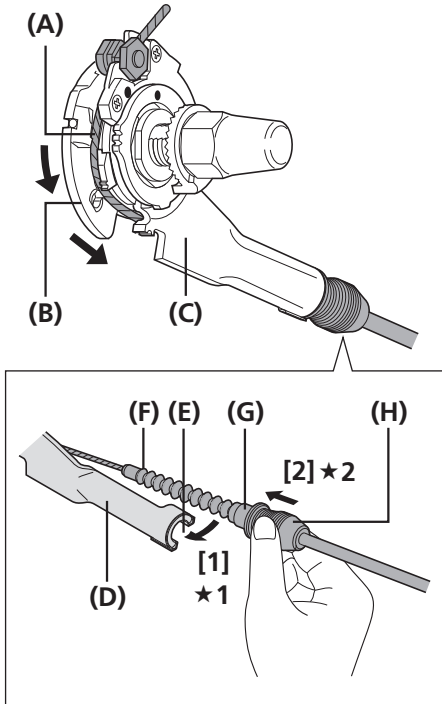

- ★1 Insert the rubber bellows into the slit
- ★2 Attach the outer casing holder

- (A) Inner cable
- (B) Pulley
- (C) Bracket
- (D) Outer casing holder section
- (E) Slit
- (F) Rubber bellows
- (G) Outer casing holder
- (H) Rubber cover

NOTE

Check that the inner cable is correctly seated inside the pulley guide.

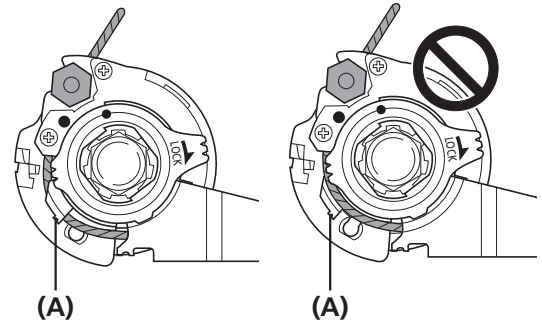

(A) Guide

TECH TIPS

When it is easier to insert the outer casing holder into the outer casing holder section of the cassette joint

Insert the outer casing holder into the outer casing holder section of the cassette joint [1]. Next, insert a 2 mm hexagon wrench or a #14 spoke into the hole in the cassette joint pulley and turn the pulley [2] so that the inner cable fixing bolt unit fits into the gap in the pulley [3].

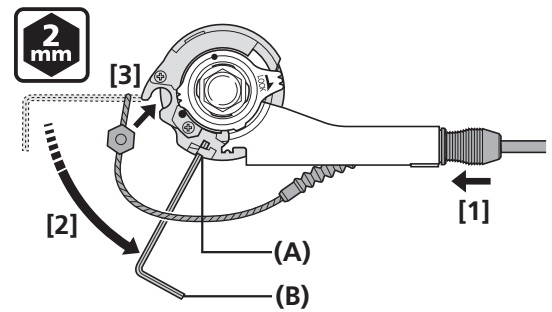

- (A) Hole in pulley
- (B) 2 mm hexagon wrench or #14 spoke

11. Finally, fix the cable on the frame with the outer casing bands.

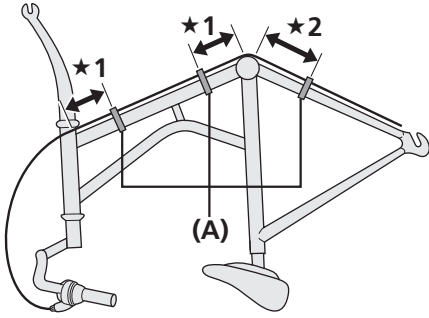

★1 10 cm

★2 15 cm

(A) Outer casing bands

ADJUSTMENT

ADJUSTMENT

Adjusting the cassette joint

1. Repeatedly move the REVOSHIFT lever/shifting lever from the low position to the top position to condition the shifting cable.

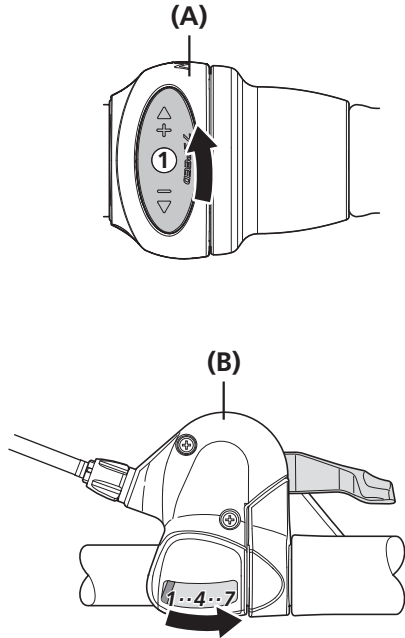

- (A) REVOSHIFT lever
- (B) RAPIDFIRE Plus shifting lever

2. Set the REVOSHIFT lever/shifting lever to 1.

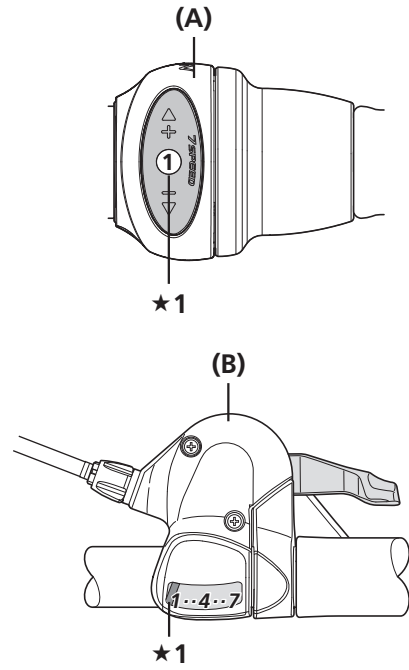

★1 Set to 1

- (A) REVOSHIFT lever
- (B) RAPIDFIRE Plus shifting lever

3. Set the REVOSHIFT lever/shifting lever as shown in the illustration.

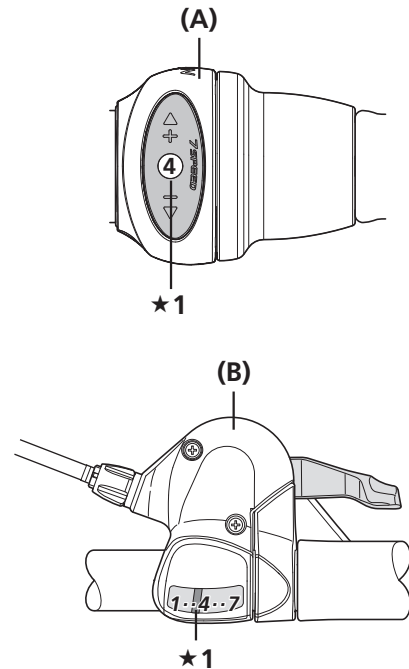

★1 7-speed/8-speed hub: Set to 4
5-speed hub: Set to 3

- (A) REVOSHIFT lever
- (B) RAPIDFIRE Plus shifting lever

4. Check that the yellow setting lines on the cassette joint bracket and pulley are aligned with each other. If the overlapping area falls short of two thirds of each setting line, the gears may not be properly engaged during pedaling, resulting in abnormal noise or free spinning of the pedals.

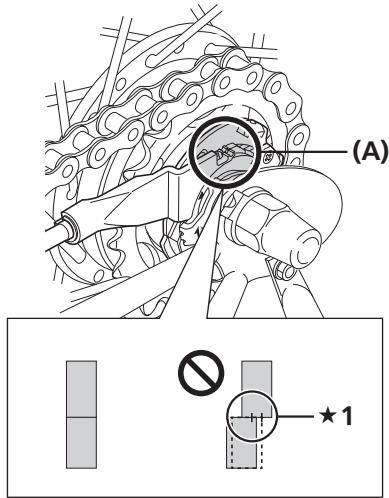

★1 The overlapping area falls short of two thirds of each setting line

(A) Yellow setting lines

TECH TIPS

The yellow setting lines on the cassette joint are located in two places. Use the one that is easiest to see.

When the bicycle is upright

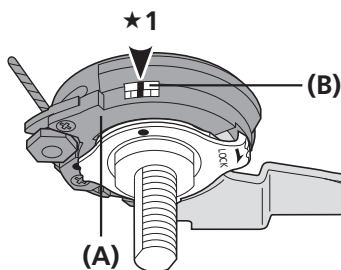

★1 Should be aligned

(A) Bracket
(B) Pulley

When the bicycle is upside down

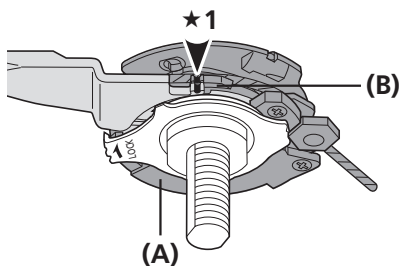

★1 Should be aligned

(A) Bracket
(B) Pulley

TECH TIPS

If the yellow setting lines are not aligned

Turn the cable adjustment barrel of the REVOSHIFT lever/shifting lever to align the setting lines. After this, move the REVOSHIFT lever/shifting lever once more from X to Y and then back to X, and then re-check to be sure that the yellow setting lines are aligned.

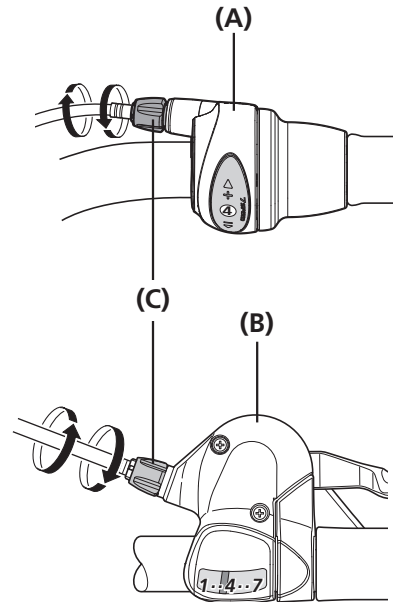

(A) REVOSHIFT lever
(B) Shifting lever
(C) Cable adjustment barrel

	X	Y
8-speed	4	1
7-speed	4	1
5-speed	3	1

5. After adjusting the cassette joint, cut off the excess length of inner cable. Next, install the inner end cap.

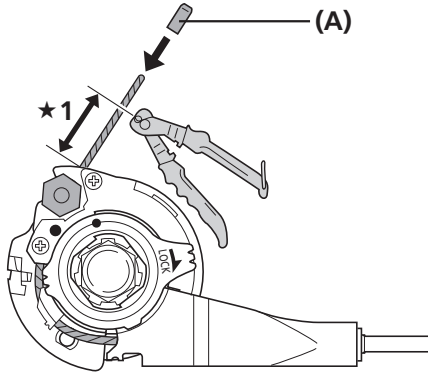

★1 15 - 20 mm

(A) Inner end cap

MAINTENANCE

MAINTENANCE

Disconnecting the shifting cable when removing the rear wheel from the frame

■ For CJ-NX10/CJ-8S20

Disconnect the cable from the cassette joint when removing the rear wheel from the frame.

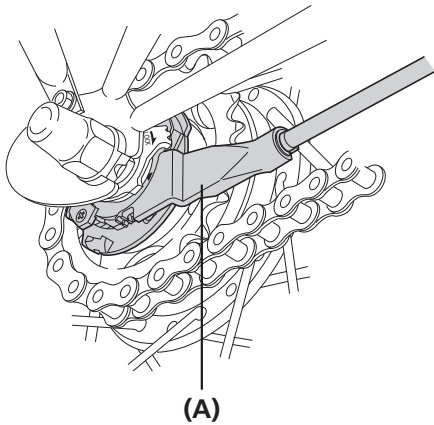

(A) Cassette joint

1. Set the REVOSHIFT lever/shifting lever to 1.

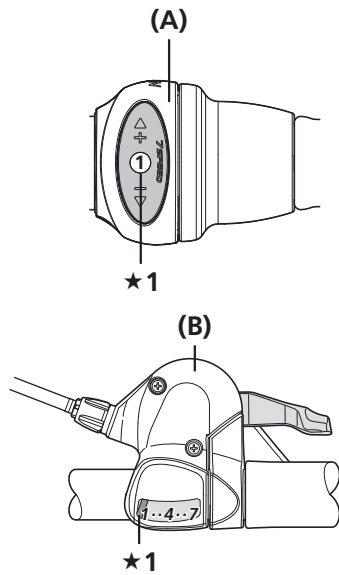

★1 Set to 1
 (A) REVOSHIFT lever
 (B) RAPIDFIRE Plus shifting lever

2. Pull out the outer casing from the outer casing holder of the cassette joint, and remove the inner cable from the slit in the bracket.

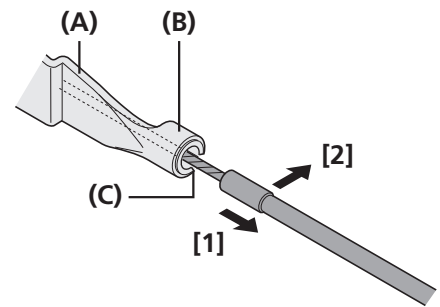

(A) Bracket
 (B) Outer casing holder
 (C) Slit

- Remove the inner cable fixing bolt unit from the cassette joint pulley.

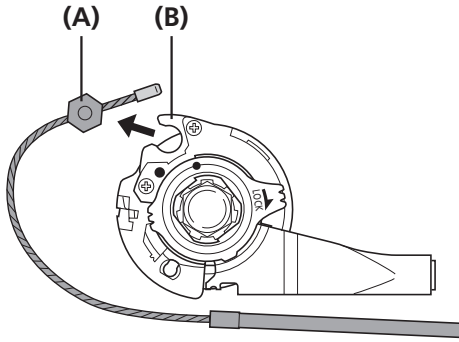

(A) Inner cable fixing bolt unit
(B) Cassette joint pulley

TECH TIPS

When it is difficult to remove the outer casing from the outer casing holder of the cassette joint

Insert a 2 mm hexagon wrench or a #14 spoke into the hole in the cassette joint pulley and turn the pulley to slacken inner cable [1].

First, remove the inner cable fixing bolt unit from the pulley [2], and then remove the outer casing from the outer casing holder [3].

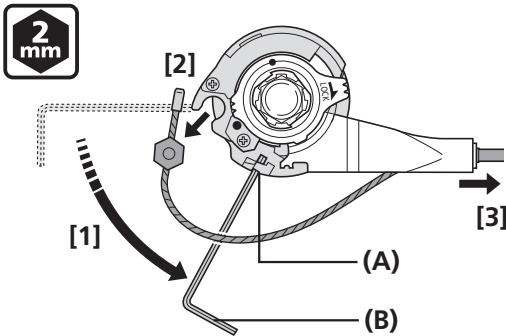

(A) Hole in pulley
(B) 2 mm hexagon wrench or #14 spoke

* When remounting the cable, refer to the section "Installation of the shifting cable".

■ For CJ-NX40/CJ-8S40

Disconnect the cable from the cassette joint when removing the rear wheel from the frame.

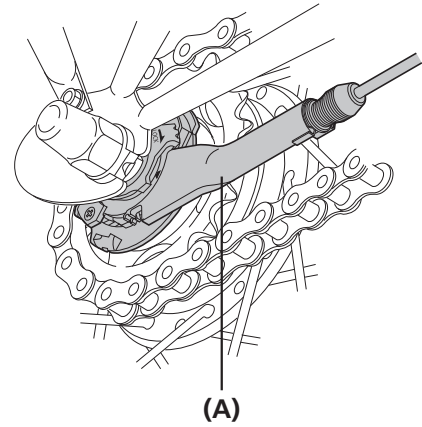

(A) Cassette joint

- Set the REVOSHIFT lever/shifting lever to 1.

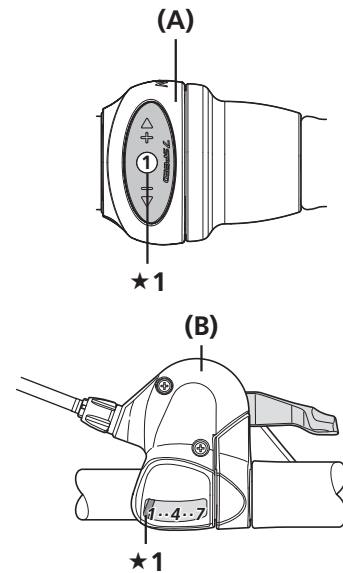

★1 Set to 1

(A) REVOSHIFT lever
(B) RAPIDFIRE Plus shifting Lever

2. Hold the rubber cover and pull the outer casing holder out from the outer casing holder section of the cassette joint [1].

Remove the rubber bellows portion of the inner cable from the slit in the bracket [2].

Be careful not to damage the rubber bellows at this time.

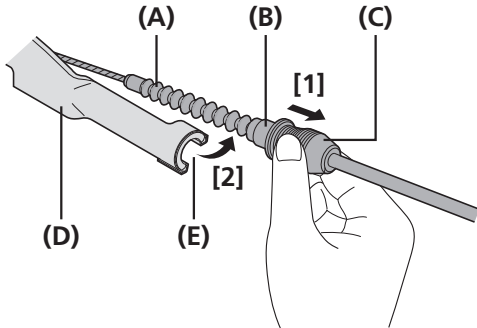

- (A) Rubber bellows
- (B) Outer casing holder
- (C) Rubber cover
- (D) Outer casing holder section
- (E) Slit

NOTE

Do not remove the cable by pulling the outer casing.

3. Remove the inner cable fixing bolt unit from the cassette joint pulley.

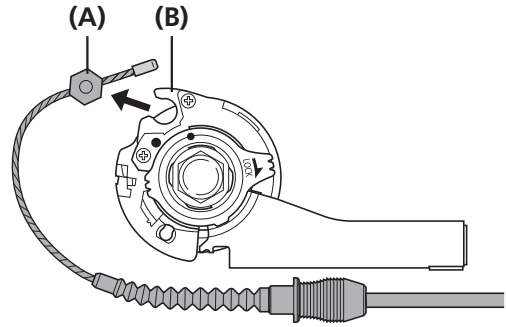

- (A) Inner cable fixing bolt unit
- (B) Cassette joint pulley

TECH TIPS

When it is difficult to remove the outer casing holder from the outer casing holder section of the cassette joint

Insert a 2 mm hexagon wrench or a #14 spoke into the hole in the cassette joint pulley and turn the pulley to slacken inner cable [1].

First, remove the inner cable fixing bolt unit from the pulley [2], and then remove the outer casing holder from the outer casing holder section [3].

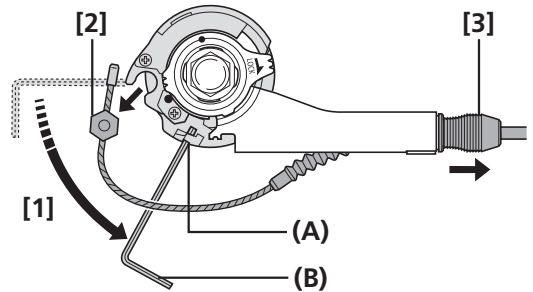

- (A) Hole in pulley
- (B) 2 mm hexagon wrench or #14 spoke

Replacing the inner cable

■ REVOSHIFT lever

1. Set the REVOSHIFT lever to 1.

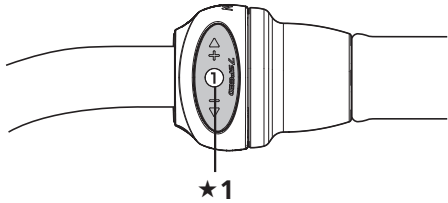

★1 Set to 1

2. Loosen the cover fixing screws, and then remove the cover.

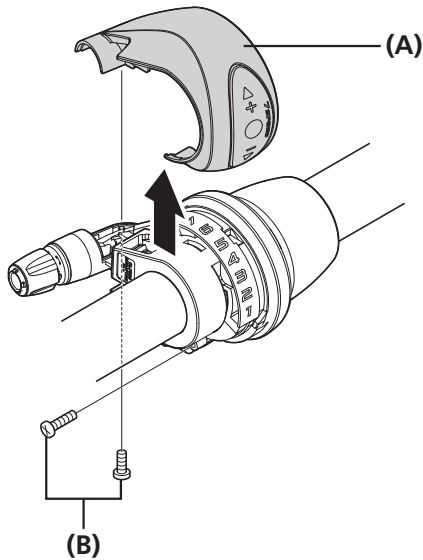

(A) Cover
(B) Cover fixing screw

3. Remove the inner cable fixing bolt unit from the cassette joint pulley.

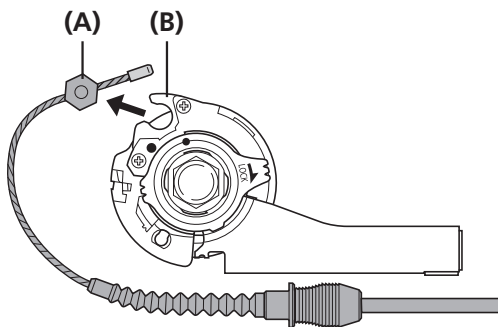

(A) Inner cable fixing bolt unit
(B) Cassette joint pulley

4. Pass the inner cable from the hole in the winder unit through the hole in the cable adjustment barrel. Next, insert the inner cable into the groove of the cable guide. Next, pull the inner cable so that the inner cable drum fits into the recess in the winder unit.

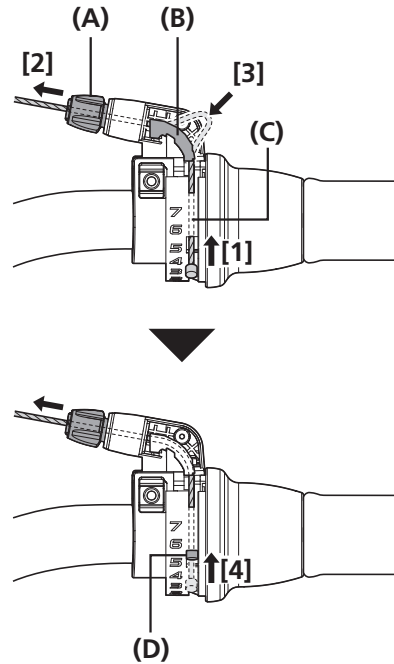

(A) Hole in cable adjustment barrel
(B) Groove of cable guide
(C) Hole in winder unit
(D) Recess in winder unit

5. Replace the cover and tighten the cover fixing screws.

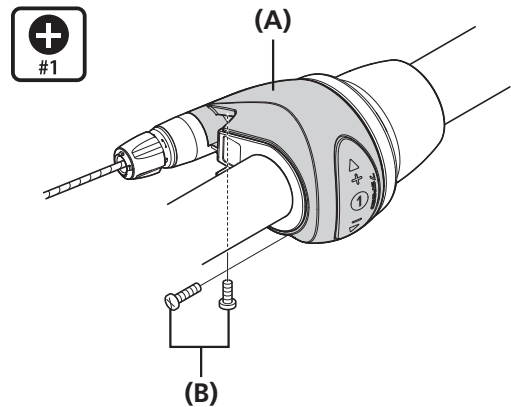

(A) Cover
(B) Cover fixing screw

Tightening torque

Screwdriver[#1]

0.1 - 0.2 N·m

For SB-8S20-A

1. Set the REVOSHIFT lever to 1.

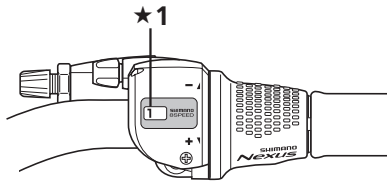

★1 Set to 1

2. Loosen the cover fixing screws, and then remove the cover.

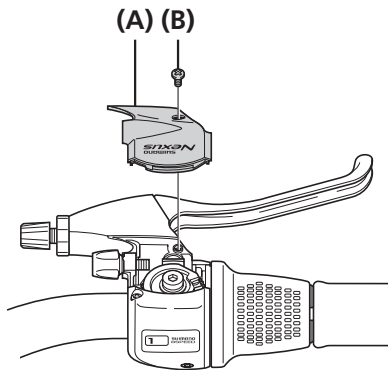

(A) Cover
(B) Cover fixing screw

3. Remove the inner cable fixing bolt unit from the cassette joint pulley.

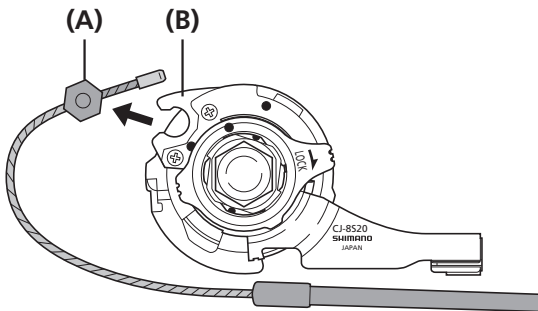

(A) Inner cable fixing bolt unit
(B) Cassette joint pulley

4. Pass the inner cable through the hole in the cable adjustment barrel. Next, hook the inner cable into the groove in the pulley, and pull the inner cable so that the inner cable drum fits into the hole in the pulley.

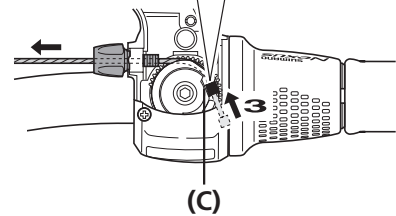
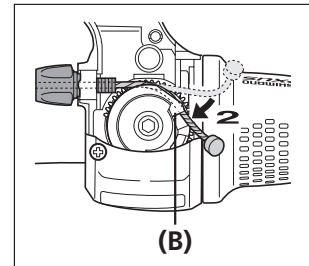
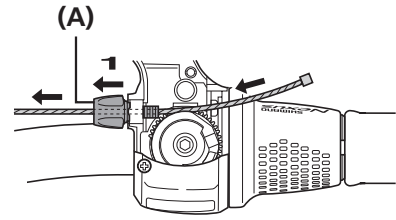

(A) Hole in cable adjustment barrel
(B) Groove in pulley
(C) Hole in pulley

5. Replace the cover and tighten the cover fixing screws.

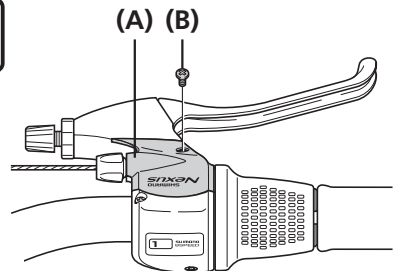

(A) Cover
(B) Cover fixing screw

Tightening torque

Screwdriver[#1]

0.2 - 0.4 N·m

For SB-C3000-7

1. Set the REVOSHIFT lever to 1.

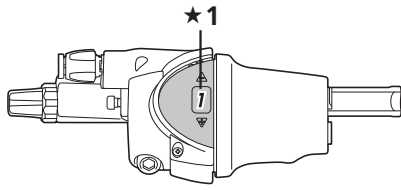

★1 Set to 1

2. Loosen the cover fixing screws, and then remove the cover.

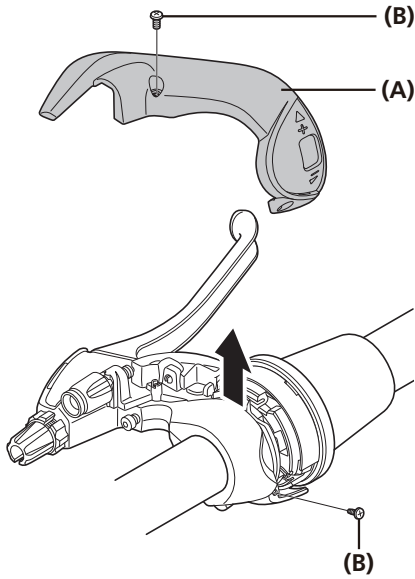

(A) Cover
(B) Cover fixing screw

3. Remove the inner cable mounting bolt unit from the cassette joint pulley.

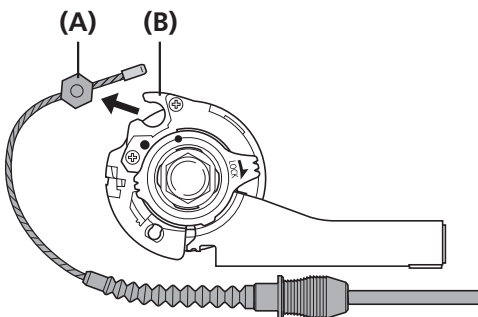

(A) Inner cable mounting bolt unit
(B) Cassette joint pulley

4. Pass the inner cable from the hole in the winder unit through the hole in the cable adjustment barrel. Next, insert the inner cable into the groove of the cable guide. Next, pull the inner cable so that the inner cable drum fits into the recess in the winder unit.

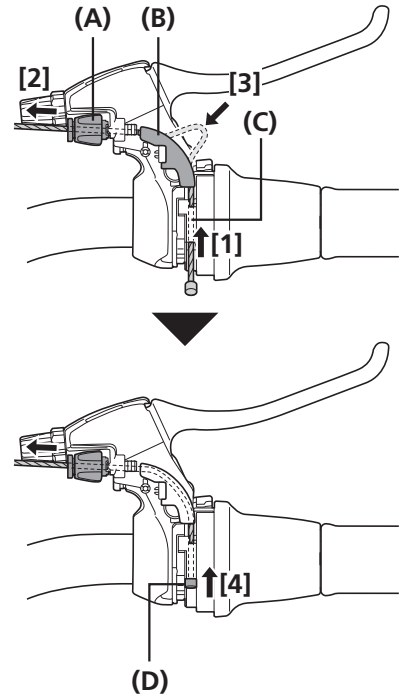

(A) Hole in cable adjustment barrel
(B) Groove of cable guide
(C) Hole in winder unit
(D) Recess in winder unit

5. Replace the cover and tighten the cover fixing screws.

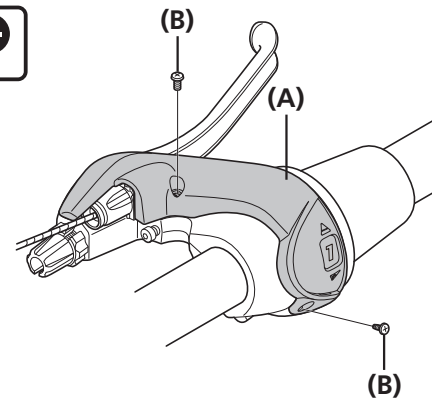

(A) Cover
(B) Cover fixing screw

Tightening torque

Screwdriver[#1]

0.1 - 0.2 N·m

■ RAPIDFIRE Plus Shifting lever

1. Set the shifting lever to 1.

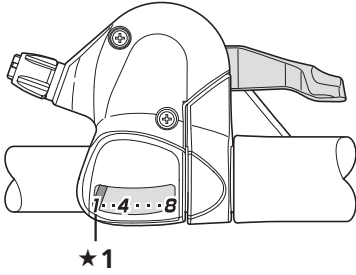

★1 Set to 1

2. Loosen and remove the wire end hooking cap.

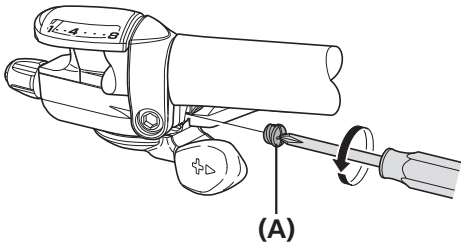

(A) Wire end hooking cap

3. Remove the inner cable fixing bolt unit from the cassette joint pulley.

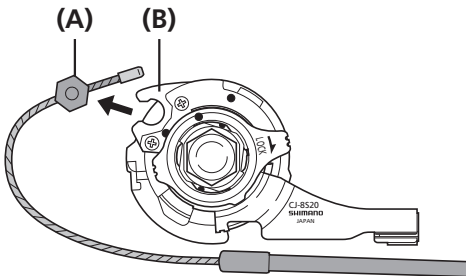

(A) Inner cable fixing bolt unit
(B) Cassette joint pulley

4. Insert the inner cable into the groove in the winder unit, and then pass it through the hole in the cable adjustment barrel. Next, pull the inner cable so that the inner cable drum fits into the recess in the winder unit.

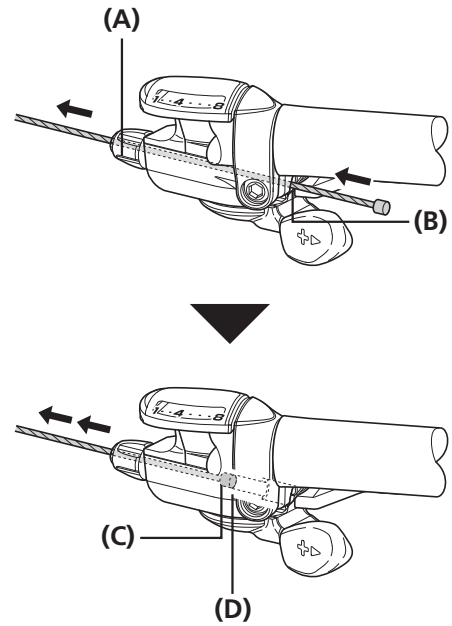

(A) Hole in cable adjustment barrel
(B) Groove in winder unit
(C) Inner cable drum
(D) Recess in winder unit

5. Screw in the wire end hooking cap as shown in the illustration until it stops turning. If it is turned any further, it will damage the screw threads in the cover. In addition, the unit cover may become bent, which may cause an obstruction between the unit cover and lever A, causing lever A to not operate correctly. If lever A does not return properly, loosen the wire end hooking cap slightly to make a gap between lever A and the unit cover, and check that this improves the returning of lever A.

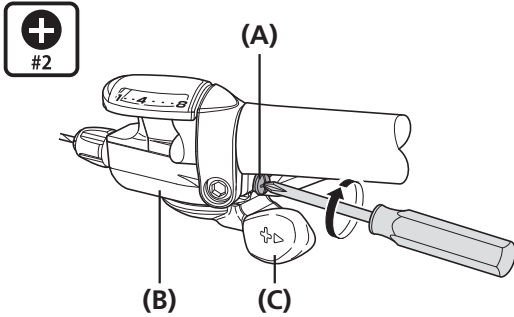

- (A) Wire end hooking cap
- (B) Unit cover
- (C) Lever A

Tightening torque

Screwdriver[#2]

0.3 - 0.5 N·m

Replacement and assembly of the indicator unit

■ Removal

Disassembly and assembly should only be carried out when removing or replacing the indicator unit.

1. Operate lever B and set it to 1.
2. Loosen and remove the two cover fixing bolts that are securing the indicator unit.
3. Remove the indicator unit as shown in the illustration.

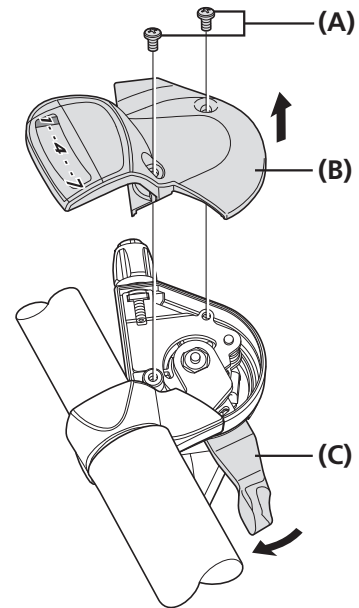

- (A) Cover fixing bolt
- (B) Indicator unit
- (C) Lever B

Installation

Disassembly and assembly should only be carried out when removing or replacing the indicator unit.

1. Check that the needle of the indicator is on the left side (positioned at 1) and then install the indicator unit so that it is facing straight upward. Insert the axle of the pin plate that is protruding from the bottom of the indicator unit into the hole in the winder unit at this time.

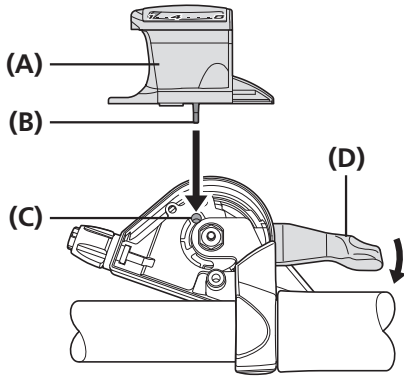

- | | |
|-----|---------------------------------------|
| (A) | Indicator unit |
| (B) | Axle of pin plate |
| (C) | Hole in winder unit (positioned at 1) |
| (D) | Lever B |

2. Secure the indicator unit with the two cover fixing bolts.

Tightening torque

Screwdriver[#2]

0.3 - 0.5 N·m

3. Operate lever A and lever B, and check their operation. If they do not operate correctly, reinstall the indicator unit while taking particular note of step 1 above.

NOTE

Do not disassemble the indicator unit or the shifting lever unit. Disassembling them may result in malfunctions.

Oil maintenance of the internal assembly

To maintain the product in good working order, it is recommended to have the place of purchase or a distributor carry out maintenance such as lubrication of the internal parts about once a year from the first time of use (once every 2,000 km if the bicycle is used very frequently). If the bicycle is used under harsh conditions, more frequent maintenance is required. Also, for carrying out maintenance, the use of SHIMANO internal geared hub grease or a lubrication kit is recommended. If SHIMANO grease or a SHIMANO lubrication kit is not used, problems such as a malfunction in gear shifting may occur.



(A)

(A) WB maintenance oil set (Y00298010)

1. Fill the container with maintenance oil to a height of 95 mm.



★1 95 mm

2. Immerse the internal unit in the oil from the left side until the oil reaches up to ring gear unit 1, as shown in the illustration.



★1 Ring gear unit 1

3. Keep the internal unit immersed for approximately 90 seconds.



4. Remove the internal unit from the oil.



5. Let excess oil drain off for approximately 60 seconds.



6. Reassemble the hub.



SHIMANO

SHIMANO NORTH AMERICA BICYCLE, INC.

One Holland, Irvine, California 92618, U.S.A. Phone: +1-949-951-5003

SHIMANO EUROPE B.V.

High Tech Campus 92, 5656 AG Eindhoven, The Netherlands Phone: +31-402-612222

SHIMANO INC.

3-77 Oimatsu-cho, Sakai-ku, Sakai City, Osaka 590-8577, Japan

Please note: specifications are subject to change for improvement without notice. (English)

© Apr. 2020 by SHIMANO INC. ITP